

B2320 Glass Backboard Upgrade Kit

1. Lower backboard to lowest position.
2. Remove Rim Cover Plate. See Figure 1.
3. Remove Rim.

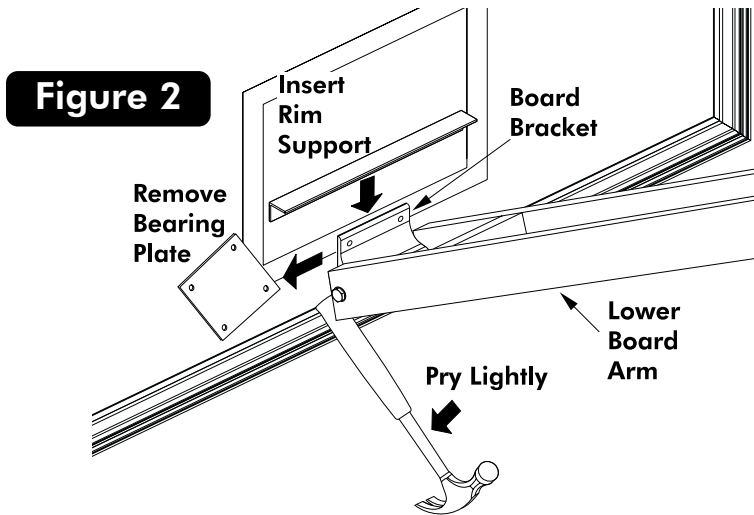
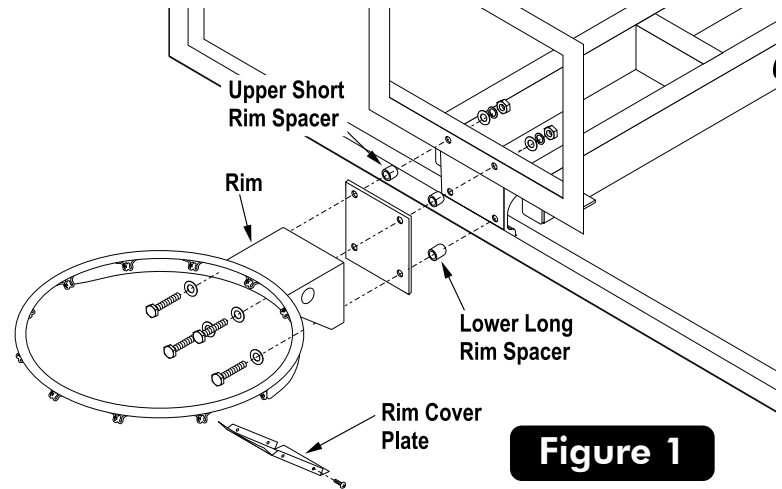

4. Remove Bearing Plate by carefully prying on Lower Board Arm. See Figure 2.
5. Insert Rim Support by carefully prying on lower board arm. Ensure holes in Rim Support line up with holes in Board Bracket.
6. Remove lower Rim Spacers and replace with LONG Rim Spacers provided. See Figure 1. **Note: Upper holes still require SHORT Rim Spacers.**
7. Reattach Rim.
8. Reattach Rim Cover Plate.

Contact Escalade® Sports customer service department at:

Phone: 1-888-USA-GOAL Toll – Free !

Fax: 1-866-873-3536 Toll – Free !

E-mail: basketball@escaladesports.com

Mailing Address:

Escalade Sports

PO Box 889

Evansville, IN 47706

Please visit our World Wide Web site at: www.escaladesports.com

ON-LINE TROUBLE SHOOTING

TECHNICAL ASSISTANCE

ON-LINE PARTS REQUESTS

FREQUENTLY ASKED QUESTIONS

ADDITIONAL ESCALADE® SPORTS PRODUCT INFORMATION

ESCALADE®
SPORTS